

**INSTALLATION INSTRUCTIONS**

DESCRIPTION: Tank Pad  
 PART NUMBER: B3L-F41D0-T0  
 MODEL: '20~ YZF-R1



**⚠ WARNING**

Please read and understand these instructions completely before installation to avoid possible injury, or damage to the accessory or vehicle.

**DEALER OR INSTALLER:**  
 These instructions contain important information for future reference and must be given to the customer.

**WARRANTY INFORMATION:**

In the United States, see your authorized Yamaha dealer for a copy of the Yamaha Genuine Parts and Accessories Limited Warranty.



**Note:** Tank Pad material is patented.

**NOTICE:**

Thoroughly clean the install area on the tank with isopropyl alcohol. Apply with clean hands, as dirt or grease may damage the adhesive.

- Adhesive works best when installed at a temperature between 70°F and 100°F. Do not apply if the temperature is below 59°F as the pad may not adhere to the tank. The pad should be stored at or brought up to a temperature of 72° F for at least 72 hours before installation.
- The adhesive on the tank pad requires 1 hour to cure 75 % and 72 hours to cure completely. Operating the vehicle before the adhesive has fully cured may cause the pads to peel or slip out of place.

**PARTS LIST:**

No.	Part Number	Description	Qty
--	B3L-F41D0-T0	Tank Pad Kit	--
①	*	Tank Pad Set	1
②	*	Installation Tape	1

\* Part supplied with kit only and not available separately.

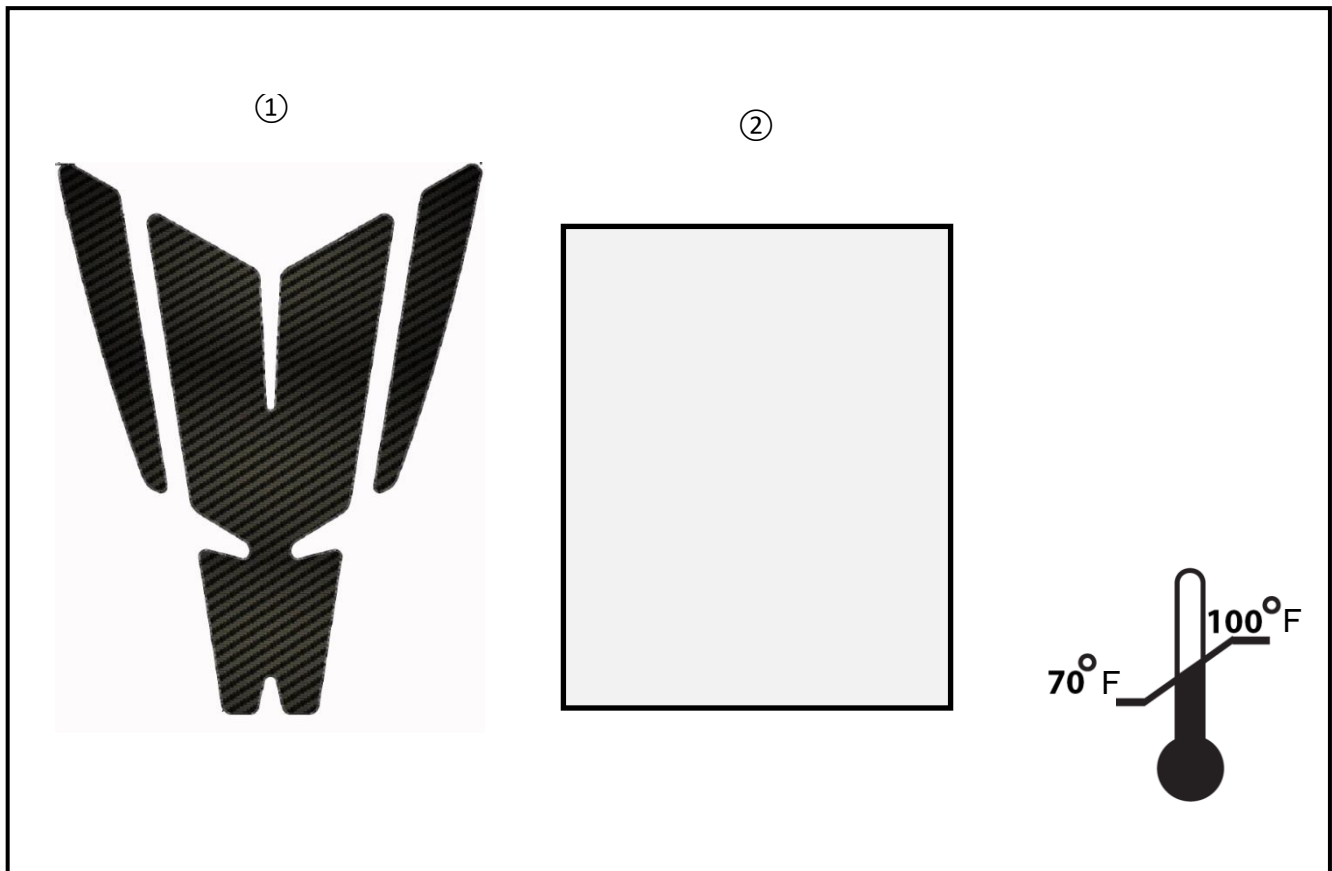

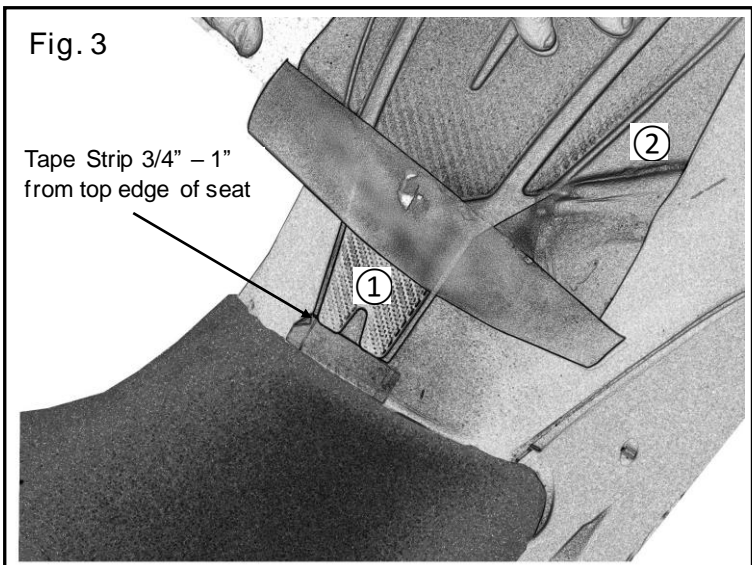
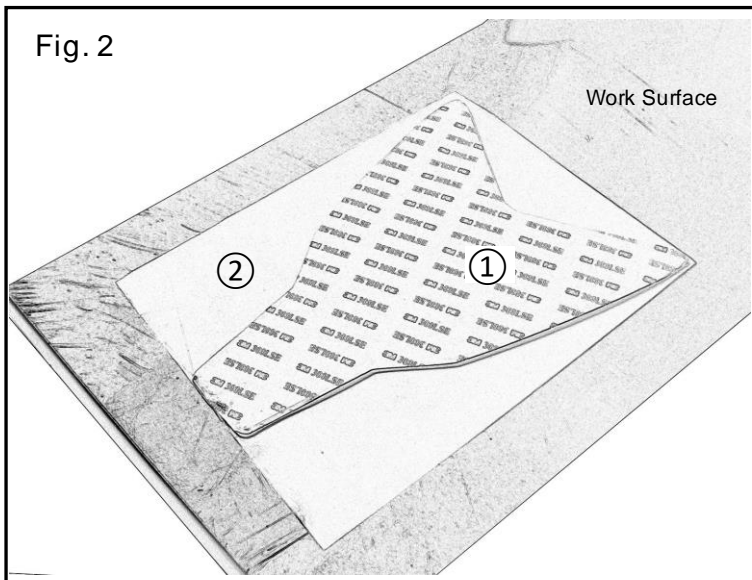
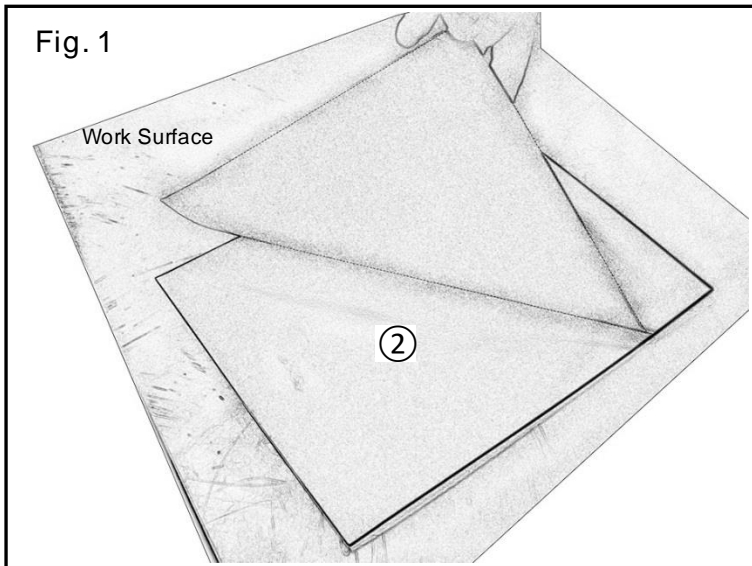

**PREPARATION:**

- Stand motorcycle on a secure and level surface.
- Clean all mounting surfaces before beginning installation, taking care to ensure all oil and dirt is removed from tank area. Ensure the tank surface is completely dry before installing the kit.

**INSTALLATION:**

1. Remove the ② Installation Tape from the backing as shown in Fig. 1.
2. Place the ② Installation Tape (adhesive facing up) on a work surface and place the ① Tank Pad face down onto the adhesive surface of the Installation Tape as shown in Fig. 2.
3. Test fit the Tank Pad/Installation Tape to the tank. Use a piece of 'blue tape' to mark a spot between 3/4" and 1" above the edge of the riders seat as shown in Fig. 3. Locate the upper right and upper left edge of the tank pad and place strips of 'blue tape' on the tank that mark the top of the left and the top of the right sides of the tank pads.

**NOTICE:** The left and right side pads must be installed just to the outside of the contour bend line of the tank– as shown in Fig. 6

4. Place the ① Tank Pad/ ② Installation Tape (dry side down) on the work surface and carefully remove the adhesive backing from the ① Tank Pad as shown in Fig. 4.
5. Use the top tape marks you installed during step 3 and position the ① Tank Pads on the Tank. When satisfied that the position is centered, square, and that the two side pads do not wrap over the contour line – press down to seat and seal the pads to the tank. Start in the center and work towards the edges and sides as shown in Fig. 5. Work out any air bubbles as you apply the pad.

Note: Apply pressure to all edges to ensure adhesion.

6. Remove the Installation Tape from the Tank Pad and remove the 'blue tape' strips installed to the tank surface in step 3.

Fig. 4

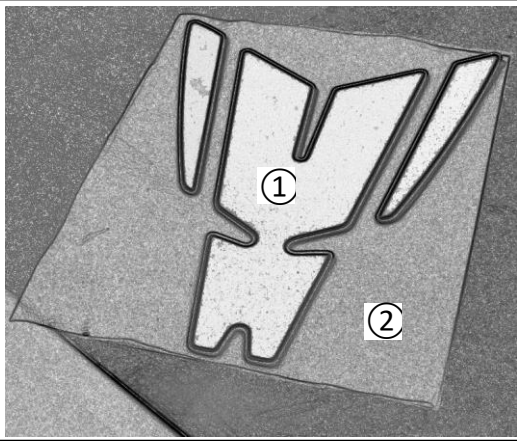

**MAINTENANCE:**  
None required after installation.

**CARE AND CLEANING:**  
Clean with a clean soft cloth and mild soap and water solution.

**CUSTOMER SERVICE:**  
For further information see your Yamaha dealer.

**ESTIMATED TIME TO INSTALL: 0.2 HRS**

Fig. 5

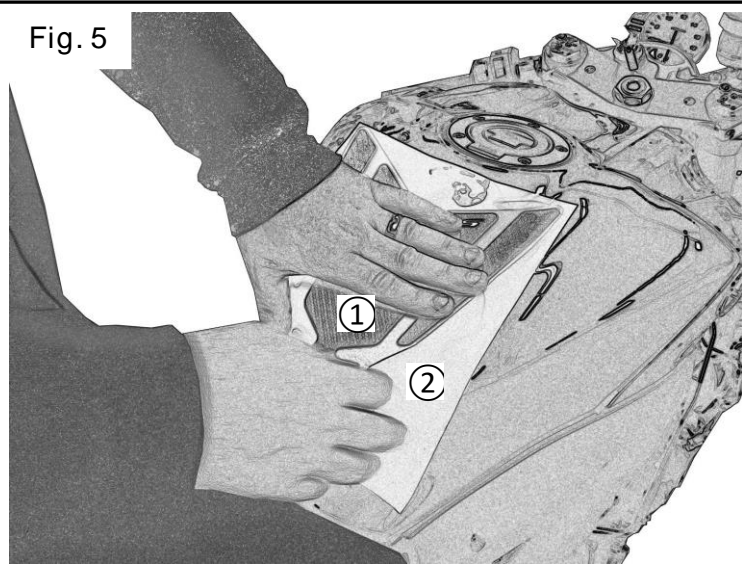
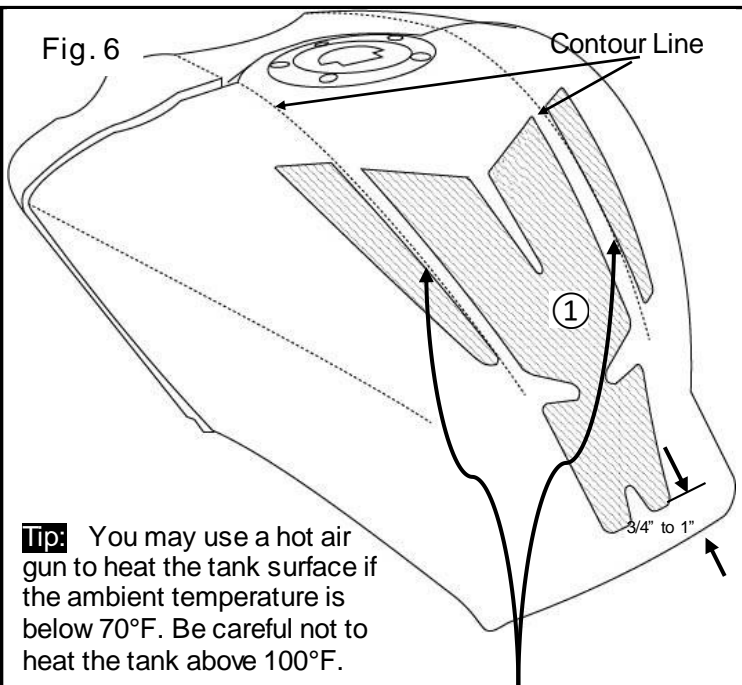

Fig. 6



**Tip:** You may use a hot air gun to heat the tank surface if the ambient temperature is below 70°F. Be careful not to heat the tank above 100°F.

**NOTICE:** Install pads so that they are not 'wrapped' over the Contour Lines of the tank.